



# SATURN

160-200 kVA

STAND ALONE THREEPHASE UPS

3:3

The ideal solution for:

- ✓ DATA CENTER
- ✓ TELECOMMUNICATIONS
- ✓ INDUSTRIAL APPLICATIONS
- ✓ TRANSPORT

**DALE**  
POWER SOLUTIONS

IN PARTNERSHIP WITH



# OVERVIEW

SATURN is the medium-high power **threephase UPS** equipped with Power Factor 1 for 160–200 kVA versions, and characterized by high operating efficiency, up to **96% in Online Mode**.

The system is made with the latest generation technologies and designed to supply a wide range of devices such as server, data centre, telecommunication and security systems.

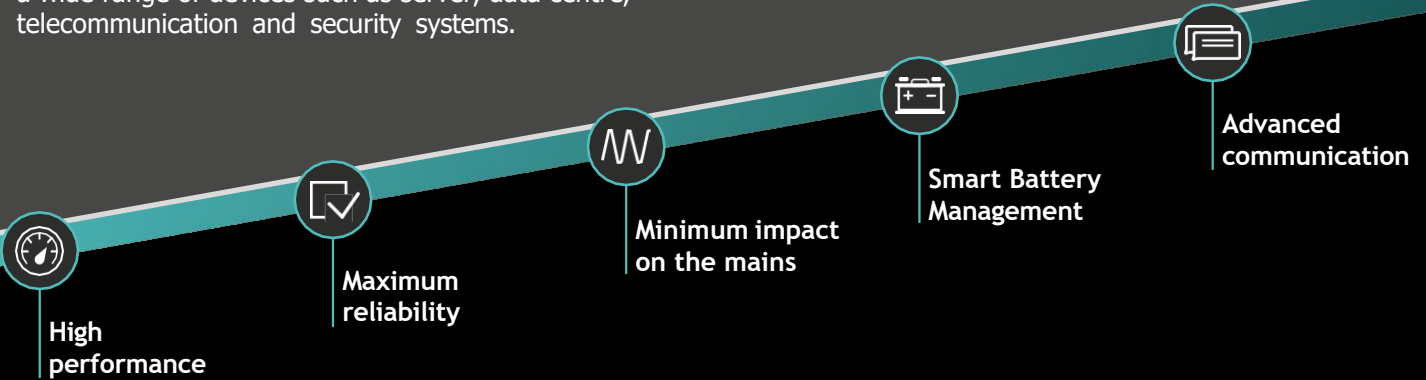

## OPERATING MODE

SATURN is an online double conversion UPS in accordance with VFI-SS-111 classification, as defined by the IEC EN 62040-3 standard. The system provides different usage modes:

### ONLINE MODE

The load is supplied by inverter through the double conversion of energy from the mains.

### ECO MODE

The load is supplied by the emergency mains and, in case of out of tolerance values, power is automatically transferred to the inverter.

### FREQUENCY CONVERTER

It's possible to use the UPS as a frequency converter from 50Hz to 60Hz or vice versa, both with or without internal batteries. In this condition, the static bypass is disabled.

### SMART ACTIVE

The UPS automatically determines whether to operate in Online Mode or in Eco Mode according to the collected statistical data of the mains.

## INTERNAL UPS CONFIGURATION

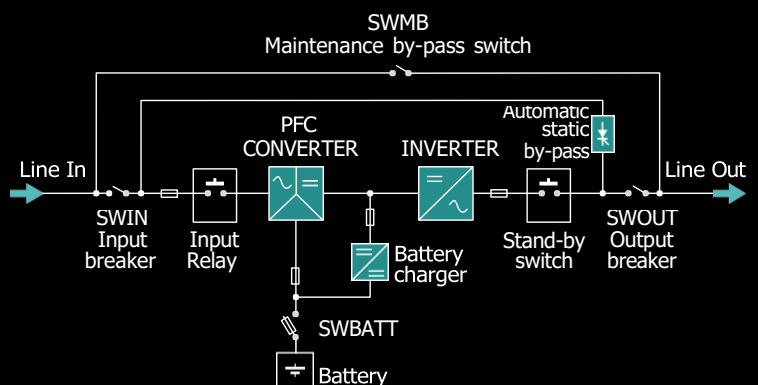

# PRODUCT RANGE



## SATURN 160-200 KVA

SATURN series is available in **160** and **200** kVA power sizes with **Power Factor 1**.

The system is able to achieve a **96% efficiency** in Normal mode.

## TECHNOLOGY

The SATURN threephase series integrates the best technology available on the market. The system is made indeed with avant-garde components and state-of-the-art technology, which ensure high performance and efficiency, thus allowing also significant operating costs saving.

**3 level IGBT inverter:** increases system efficiency while minimising energy consumption

**Cold Start Function:** the UPS can be switched-on in case of mains absence too

**Dual input:** it allows to have two mains supply line available (this is a standard feature for both 160 and 200 kVA versions)

**Smart ventilation:** both 160 and 200 kVA models have been equipped with ventilation special features, in order to increase control and efficiency

**DSP microprocessor control:** it guarantees maximum load protection, without impact on the supply line, and significant energy savings at the same time

# MAIN FEATURES

## MINIMUM IMPACT ON THE MAINS

SATURN is designed to have a nearly zero impact on the power source, both by mains or generator.

That's possible thanks to:

- Input rectifier with PFC;
- DSP microprocessors;
- IGBT power components;
- Possibility to set **START DELAY**, programmable from 1 to 120 seconds;
- Possibility to set a **SOFT START** of input rectifier, programmable from 1 to 125 secs programmable.

SATURN acts also as a filter since it eliminates harmonic components and reactive power.

## SMART BATTERY MANAGEMENT

SATURN is equipped with an advanced battery monitoring system that, through specific functions, carefully check batteries status and optimizes batteries performance, thus lengthening the operating lifetime.

Battery management provides:

- **Temperature control (optional) and voltage recharging balance**, in order to avoid batteries excessive recharge and overheating;
- **Scheduled battery test** to diagnose in advance any reduction in terms of performance or other kind of problem with batteries;
- **Protection against slow discharge** during extended low-load discharges the end-of-discharge voltage is increased to prevent damage or reduced battery performance;
- **Low ripple current** thanks to high frequency battery chargers;
- **Wide compatibility with different types of batteries**, such as ermetic lead acid (VRLA), opened valve AGM and Ni-Cd;
- **Battery cabinets** with different sizes and capacities in order to increase the available autonomy.

## DISPLAY LCD

The system is equipped with a **5-inch LCD display** that allows direct access to the main UPS functions.

By home screen it is possible to promptly visualize the UPS status and to understand through graphic indicators the health of the different components: rectifier, batteries, inverter and bypass. Through many dedicated functions the LCD display provides a lot of information about measures, state and alarms, with 8 different languages available.

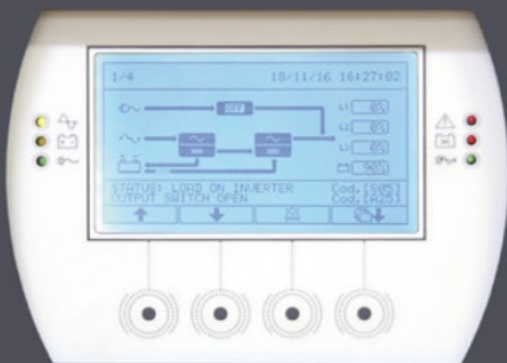

# ADVANCED COMMUNICATION

SATURN supports all operating systems and network, including monitoring software and shutdown software (UPSMON) even through SNMP card.

There are **3 slots** available for the installation of optional communication accessories such as network adapters, free contacts, etc.

There are hardware devices available like:

- **REPO (Remote Emergency Power Off)** for remote UPS switching off through emergency button;
- RS232 serial and USB ports;
- Input for the auxiliary contact connection of an external manual bypass;
- Input for an external power source synchronization.

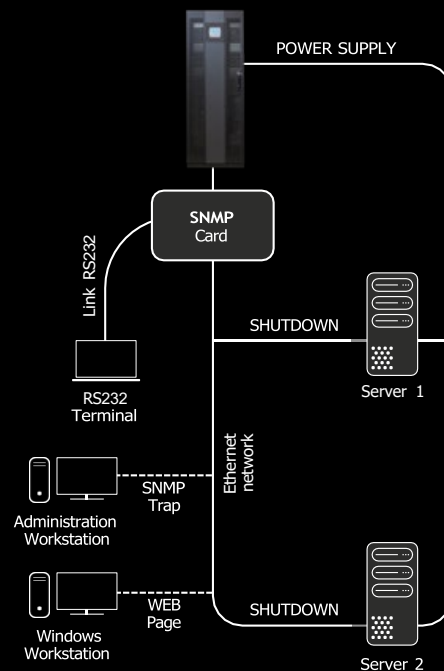

Direct Connection with Ethernet Network

# MANAGEMENT SOFTWARE

UPSMON offers easy UPS management. The software displays real-time information, shown by charts and values for critical data such as mains voltage, UPS load and battery charge.

UPSMOM allows remote interrogation of logs and operating parameters so to help diagnosing alarms and potential fault conditions. The software also allows you to perform an automatic shutdown of connected equipment, in order to always ensure maximum security level.

## SUPPORTED OPERATING SYSTEMS

Windows; Linux; Novell Netware; Mac OS; IBM OS/2; HP OPEN VMS; the most widely used UNIX operating systems such as: IBM AIX, HP UNIX, SUN Solaris INTEL and SPARC, SCO Unix and UnixWare, Silicon Graphic IRIX, Compaq Tru64 UNIX and DEC UNIX, BSD UNIX and FreeBSD UNIX, NCR UNIX.

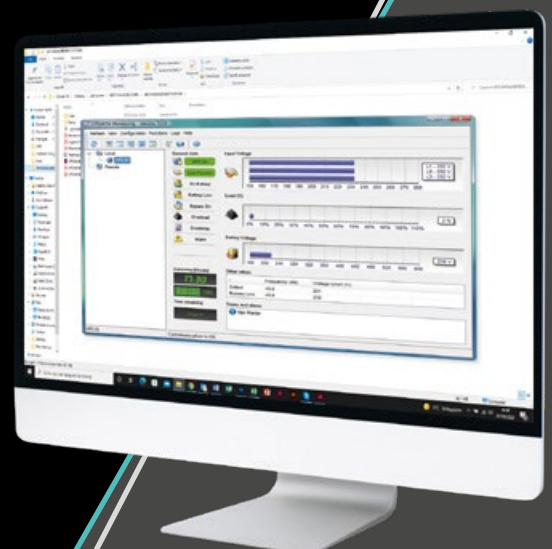

# HIGH PERFORMANCE

SATURN is designed with latest generation technologies that ensures high efficiency, up to 96%. This allows to save over 50% energy usage per year, compared to other similar products on the market.

Compact sizes make SATURN suitable for application in small spaces, keeping excellent performance and efficiency at the same time.

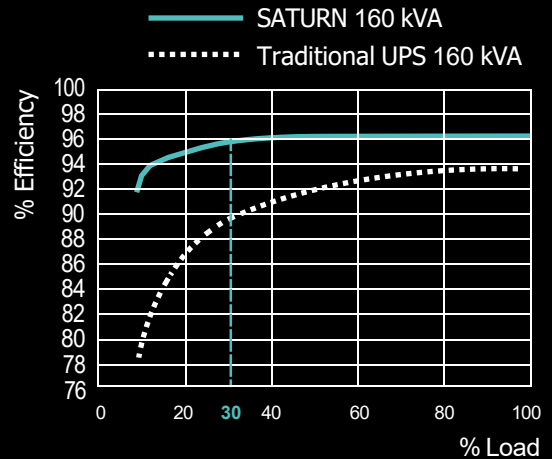

## COMPARISON

### SATURN 160 kVA

LOAD APPLIED **60%**

EFFICIENCY **96%**

ENERGY DISSIPATION **35.040 KWH**

### STANDARD UPS 160 kVA

LOAD APPLIED **60%**

EFFICIENCY **94%**

ENERGY DISSIPATION **53.678 KWH**

SAVINGS **18.638 KWH / 3.728 €**  
per year\*

\* In case of standard contract 0,20 €/kWh

# PARALLEL CONFIGURATION

The parallel redundant configuration consists in connecting more than one UPS with the same power size, linked together into a single output bus.

SATURN can work in parallel up to 6 units, with a 1200 kVA maximum power. This configuration allows proper system operation even in case of failure of one of the connected UPSs.

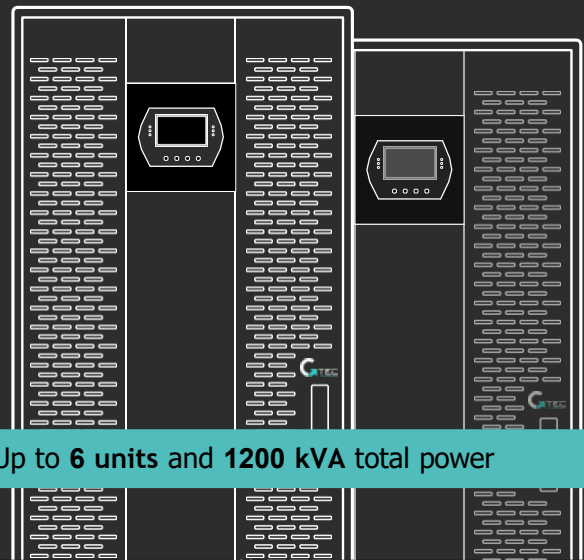

Up to 6 units and 1200 kVA total power

MODEL	ST160T	ST200T
Nominal Power	160 kVA / 160 kW	200 kVA / 200 kW
<b>MAIN INPUT</b>		
Grid system	3F+N+PE	
Rated voltage / Frequency	380/400/415 VAC, 50/60 Hz	
Voltage range	320~480 VAC full load 240~480 VAC at 50% load	
Frequency range	40~72 Hz	
Power factor	0.99	
Current THDi	≤2.5%	
<b>BYPASS INPUT</b>		
Grid system	3F+N+PE	
Rated voltage / Frequency	380/400/415 VAC, 50/60 Hz	
Voltage range	Selectable, 180 ÷ 264V	
Frequency range	Selectable, ±5 Hz	
Bypass overload	110%, long term operation 110%<load<125%, 60 minutes 125%<load<150%, 10 minutes load>150%, 1 minute	
<b>OUTPUT</b>		
Rated voltage / Frequency	380/400/415 VAC, 50/60 Hz	
Power factor	1	
Sinewave	Pure sine wave	
Voltage THDv	<0.5% (linear load); <3% (non-linear load)	
Voltage precision	±0.5%	
Transient response	±3% for resistive load	
Transient recovery	20 ms	
Inverter overload	110%, 60 minutes 125%, 10 minutes 150%, 1 minute	
Frequency regulation	50/60 Hz ±0.01%	
Synchronized range	±5% (selectable 0,5 – 10%)	
Synchronized slew rate	1 Hz/sec (selectable 0,5- 2 Hz/sec)	
Crest Factor	3:1	
<b>BATTERIES</b>		
Battery type	VRLA AGM / GEL; Ni-Cd; WET TYPE	
Number of batteries in series	40	
Nominal voltage	±240 VDC	
Batteries arrangement	External	
<b>PERFORMANCE</b>		
Efficiency - Normal operation	95,9%	95,6%
Efficiency - Eco Mode operation	99%	
Efficiency - Battery operation	95,5%	
Display	LED + LCD	
Protection degree	IP20	
Interface	Standard equipment: RS232, USB, dry contacts, Cold Start Optional: SNMP, parallel kit, MODBUS, PROFIBUS	
<b>ENVIRONMENT</b>		
Operating temperature	0 ~ 40 °C	
Storage temperature	-25 ~ 55 °C (UPS) -15 ~ 40 °C (UPS with batteries)	
Relative humidity	0 ~ 95% (no condensing)	
Noise (dBA at 1 meter far)	≤68 dB (Online Mode) ≤50 dB (Eco Mode)	≤70 dB (Online Mode) ≤50 dB (Eco Mode)
Altitude	<1000 m; load derated 1% for every 100 m from 1000 ~ 4000 m	
<b>MECHANICAL DATA</b>		
Dimensions W*D*H (mm)	840*1050*1900	
Weight (Kg)	450	460
Colour	Cabinet: RAL 7016 Door: RAL 7016 + RAL 7012	
Compliance	European directive: 2014/35/EU Low voltage directive; and 2014/30/EU Electromagnetic compatibility directive • Security: EN62040-1 • EMC: EN62040-2 • Performance: EN62040-3 (Voltage Frequency Independent) VFI - SS - 111	

Note: technical specifications and data could be changed without notification

# DALE

POWER SOLUTIONS

IN PARTNERSHIP WITH



**Dale Power Solutions Ltd**

Salter Road, Eastfield Industrial Estate,  
Scarborough, YO11 3DU  
Tel. 0330 999 3000  
[hello@dalepowersolutions.com](mailto:hello@dalepowersolutions.com)  
[www.dalepowersolutions.com](http://www.dalepowersolutions.com)

**GTEC Europe srl**

Strada Marosticana, 81/13  
36031 Dueville (VI), Italy  
Tel. +39 0444.361321  
[info@gtec-power.eu](mailto:info@gtec-power.eu)  
[www.gtec-power.eu](http://www.gtec-power.eu)

**GTEC France**

[france@gtec-power.eu](mailto:france@gtec-power.eu)