

LIBRA PRO

10-800 kVA

STAND ALONE THREEPHASE UPS

3:1

3:3

The ideal solution for:

- ✓ *HOSPITAL*
- ✓ *TRANSPORT*
- ✓ *TELECOMMUNICATION*
- ✓ *INDUSTRIAL APPLICATION*
- ✓ *DATA CENTRE*

DALE
POWER SOLUTIONS

IN PARTNERSHIP WITH



OVERVIEW

LIBRA PRO is the stand-alone Threephase UPS that suits high power, up to 800 kVA, with maximum sturdiness and reliability. The system, available in different configurations, all equipped with an inverter output isolation transformer, represents the ideal solution for protecting the most critical loads.

MAXIMUM RELIABILITY

LIBRA PRO series is specifically designed for mission-critical loads and ensures the highest level of reliability available on the market.

The isolation transformer, the manual bypass, and a highly efficient ventilation system are just some of the features that make LIBRA PRO an exceptionally solid UPS, which can also be configured in parallel up to 8 units.

SIMPLIFIED MAINTENANCE

LIBRA PRO's architecture has been designed to make maintenance operations as simple as possible. Wiring and key electronic components are easily accessible from the front of the cabinet, ensuring extremely short intervention times.

At the same time, the system includes replaceable wear components, such as capacitors and fans, the latter being located on the top side and therefore accessible without needing to move the UPS (for power ratings ≥ 100 kVA).



TECHNOLOGY

- Isolating transformer on the inverter
- Rectifier with IGBT technology (from 100 kVA)
- DSP (Digital Signal Processor) microprocessor control
- Intelligent battery charger system
- Manual bypass
- EPO (Emergency Power Off) system
- Walk-In mode (gradual absorption of the input current when the mains power returns)

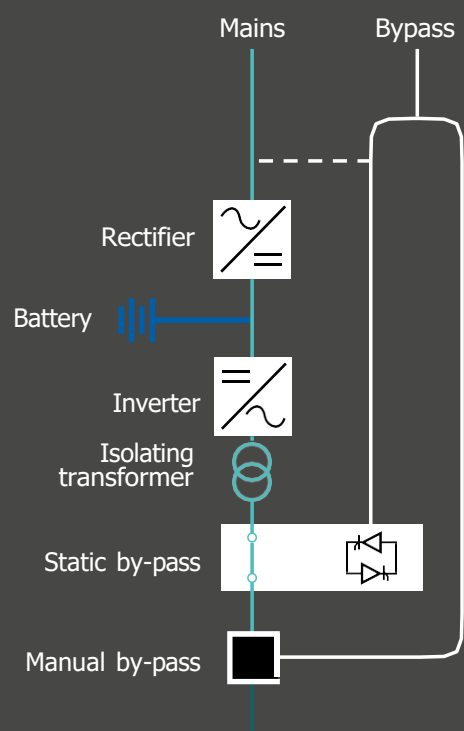

PRODUCT RANGE

LIBRA PRO 10-800 KVA

One of the strengths of LIBRA PRO is the wide range of options and accessories available, which allow for numerous different configurations and architectures.

The UPS is available in 3:1 mode for power ratings from 10 to 100 kVA, and in 3:3 mode for all power ratings up to 800 kVA. It is also possible to choose between versions with IGBT or SCR (Silicon Controlled Rectifier) rectifiers, as well as between Power Factor 1 or 0.9.

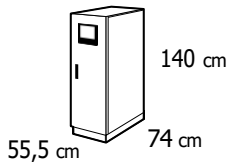

LB010MP, LB015MP, LB020MP,
LB030MP, LB040MP.

LB010TP, LB015TP, LB020TP,
LB030TP, LB040TP

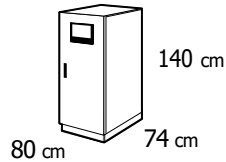

LB060MP, LB080MP, LB060TP,
LB080TP

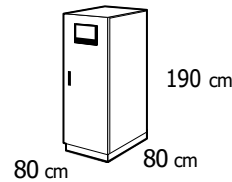

LB100MP, LB100TP, LB120TP,
LB160TP, LB200TP

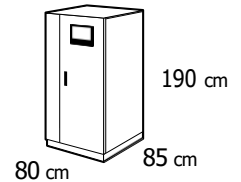

LB100IGBT, LB120IGBT,
LB100IGBTPF1, LB120IGBTPF1

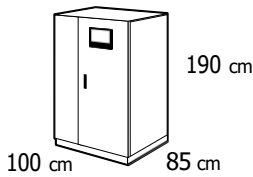

LB160IGBT, LB200IGBT,
LB250IGBT, LB160IGBTPF1,
LB200IGBTPF1, LB250IGBTPF1

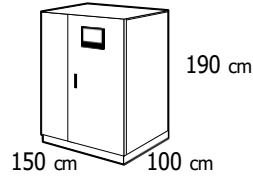

LB300IGBT, LB400IGBT,
LB300IGBTPF1, LB400IGBTPF1

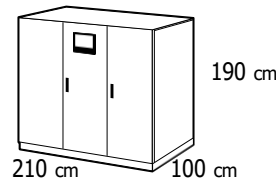

LB500IGBT, LB600IGBT,
LB500IGBTPF1, LB600IGBTPF1

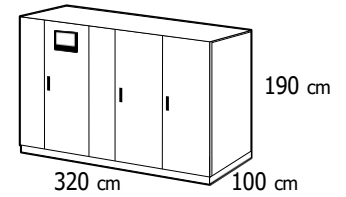

LB800IGBTPF1

COMMUNICATION

LIBRA PRO features a complete communication system. The multilingual display allows to view and set the main operating parameters, as well as select the various operating modes available:

- Normal Mode
- Parallel Configuration
- Eco Mode
- Smart Active
- Automatic Voltage Stabilizer
- Frequency Converter

The UPS is also equipped with a dual RS232 serial port and two slots for optional cards (SNMP network adapter, relay card and optional JBUS/ModBUS and ProfiBUS interface).



MODEL	LB010MP*	LB015MP*	LB020MP*	LB030MP	LB040MP	LB060MP	LB080MP	LB100MP	
Nominal Power	10 kVA / 9 kW	15 kVA / 13,5 kW	20 kVA / 18 kW	30 kVA / 27 kW	40 kVA / 36 kW	60 kVA / 54 kW	80 kVA / 72 kW	100 kVA / 90 kW	
MAIN INPUT									
Grid system	3PHS + PE								
Rated voltage / Frequency	380/400/415VAC (Phase-phase), 50/60Hz								
Voltage range	300~480 VAC								
Frequency range	45~65 Hz								
Power factor	0,9								
Current THDi	25% (5% in the version with MPF filter**)								
Power walk-in	0-100% from 0 to 120 seconds (selectable)								
Standard features	Back Feed protection and splitted bypass line								
BYPASS INPUT									
Grid system	1PH + N + PE								
Rated voltage / Frequency	220/230/240VAC (Phase-Neutral), 50/60Hz								
Voltage range	Default: -20% ~ +20% Selectable: -5% ~ +25%								
Frequency range	± 2% (selectable from 1% to 6%)								
Bypass overload	110%, 60 minutes 125%, 10 minutes 150%, 1 minute								
OUTPUT									
Grid system	1PH + N + PE								
Rated voltage / Frequency	220/230/240VAC (Phase-Neutral), 50/60Hz								
Power factor	0,9								
Voltage THDv	<1% (from 0% to 100% linear load); <3% (non-linear load according to IEC/EN 62040-3)								
Voltage precision	± 1%								
Transient response	± 5%								
Transient recovery	20ms according to standard EN 62040-3, class 1								
Inverter overload	110%, 60 minutes 125%, 10 minutes 150%, 1 minute								
Frequency regulation from battery	50/60Hz ± 0.05%								
Synchronized range	2% (adjustable from ± 1% to ± 6% from the control panel)								
Synchronized slew rate	1 Hz/sec (selectable from 0.1 to 3)								
Crest Factor	3:1								
BATTERIES									
Battery type	Pb sealed acid, Wet, Ni-Cd								
Ripple	< 1%								
Number of batteries in series	Standard: 32 batteries 12V Selectable: 31-33 batteries 12V							Standard 33/12V Sel. 32-34/12V	
Nominal voltage	384Vdc								
Typical charging current	0,1 x C10								
Numero massimo e capacità delle batterie interne	2 x 32 12V / 9Ah								-
Batteries arrangement	Internal and/or external				External				
External battery capacity	Selectable								
SYSTEM									
Efficiency - Normal operation	92%					92.5%			
Efficiency - Eco Mode operation	98%								
Efficiency - Battery operation	95%								
Display	LED + LCD								
Protection degree	IP20								
Interface	Standard equipment: double RS232 port with monitoring software CD, dry contacts, 2 interface intellislots Optional: SNMP, JBUS/ModBUS converter RS485 port, ProfiBUS converter, Multiintelligence								
ENVIRONMENT									
Operating temperature	0 ~ 40°C								
Storage temperature	-25 ~ 60°C								
Relative humidity	0 ~ 95% (no condensing)								
Noise (dBA at 1 meter far)	< 54			< 62			< 63		
Altitude	<1000m; load derated 1% per 100m, from 1000 ~ 4000m								
MECHANICAL DATA									
Dimensions W*D*H (mm)	555*740*1400				800*740*1400			800*800*1900	
Weight (Kg)	200	220	230	290	340	440	520	650	
Colour	RAL 7016								
Compliance	European directive: 2014/35/EU Low voltage directive; and 2014/30/EU Electromagnetic compatibility directive • Security: EN62040-1 • EMC: EN62040-2 • Performance: EN62040-3 (Voltage Frequency Independent) VFI - SS - 111								

Note: technical specifications and data could be changed without notification

* Also available with internal batteries

** Also available with input filter for lower current distortion (MPF version)

MODEL	LB010TP*	LB015TP*	LB020TP*	LB030TP	LB040TP	LB060TP	LB080TP	LB100TP	LB120TP	LB160TP	LB200TP	
Nominal Power	10 kVA / 9 kW	15 kVA / 13,5 kW	20 kVA / 18 kW	30 kVA / 27 kW	40 kVA / 36 kW	60 kVA / 54 kW	80 kVA / 72 kW	100 kVA / 90 kW	120 kVA / 108 kW	160 kVA / 144 kW	200 kVA / 180 kW	
MAIN INPUT												
Grid system	3PHS + PE											
Rated voltage / Frequency	380/400/415VAC (Phase-phase), 50/60Hz											
Voltage range	300~480 VAC											
Frequency range	45~65 Hz											
Power factor	0.9											
Current THDi	25% (5% in the version with TPF filter**)						30% (5% in the version with TPF filter**)					
Power walk-in	0-100% from 0 to 120 seconds (selectable)											
Standard features	Back Feed protection and splitted bypass line											
BYPASS INPUT												
Grid system	3PHS + N + PE											
Rated voltage / Frequency	380/400/415VAC (Phase-Phase), 50/60Hz											
Voltage range	Default: -20% ~ +20% Selectable: -5% ~ +25%											
Frequency range	± 2% (selectable from 1% to 6%)											
Bypass overload	110%, 60 minutes 125%, 10 minutes 150%, 1 minute											
OUTPUT												
Grid system	3PHS + N + PE											
Rated voltage / Frequency	380-400-415VAC (Phase-Phase), 50/60Hz											
Power factor	0.9											
Voltage THDv	<1% (from 0% to 100% linear load); <3% (non-linear load according to IEC/EN 62040-3)											
Voltage precision	± 1%											
Transient response	± 5%											
Transient recovery	20ms according to standard EN 62040-3, class 1											
Inverter overload	110%, 60 minutes 125%, 10 minutes 150%, 1 minute											
Frequency regulation from battery	50/60Hz ± 0.05%											
Synchronized range	2% (adjustable from ± 1% to ± 6% from the control panel)											
Synchronized slew rate	1 Hz/sec (selectable from 0.1 to 3)											
Crest Factor	3:1											
BATTERIES												
Battery type	Pb sealed acid, Wet, Ni-Cd											
Ripple	< 1%											
Number of batteries in series	Standard: 32 batteries 12V Selectable: 31-33 batteries 12V						Standard: 33 batteries 12V Selectable: 32-34 batteries 12V					
Nominal voltage	384Vdc						396Vdc					
Typical charging current	0,1 x C10											
Numero massimo e capacità delle batterie interne	2 x 32 12V / 9Ah			-								
Batteries arrangement	Internal and/or external						External					
External battery capacity	Selectable											
SYSTEM												
Efficiency - Normal operation	90.5%	91%	92%				93%		93.5%			
Efficiency - Eco Mode operation	98%											
Efficiency - Battery operation	94%						95%					
Display	LED + LCD											
Protection degree	IP20											
Interface	Standard equipment: double RS232 port with monitoring software CD, dry contacts, 2 interface intellislots Optional: SNMP, JBUS/ModBUS converter RS485 port, ProfiBUS converter, Multilicence											
ENVIRONMENT												
Operating temperature	0 ~ 40°C											
Storage temperature	-25 ~ 60°C											
Relative humidity	0 ~ 95% (no condensing)											
Noise (dBA at 1 meter far)	<54	<60	<62				63 ~ 68					
Altitude	<1000m; load derated 1% per 100m, from 1000 ~ 4000m											
MECHANICAL DATA												
Dimensions W*D*H (mm)	555*740*1400					800*740*1400			800*800*1900			
Weight (Kg)	210	220	230	280	330	450	600	640	650	770	810	
Colour	RAL 7016											
Compliance	European directive: 2014/35/EU Low voltage directive; and 2014/30/EU Electromagnetic compatibility directive • Security: EN62040-1 • EMC: EN62040-2 • Performance: EN62040-3 (Voltage Frequency Independent) VFI - SS - 111											

Note: technical specifications and data could be changed without notification

* Also available with internal batteries

** Also available with input filter for lower current distortion (TPF version)

MODEL	LB100IGBT	LB120IGBT	LB160IGBT	LB200IGBT	LB250IGBT	LB300IGBT	LB400IGBT	LB500IGBT	LB600IGBT
Nominal Power	100 kVA / 90 kW	120 kVA / 108 kW	160 kVA / 144 kW	200 kVA / 180 kW	250 kVA / 225 kW	300 kVA / 270 kW	400 kVA / 360 kW	500 kVA / 450 kW	600 kVA / 540 kW
MAIN INPUT									
Grid system	3PHS + PE								
Rated voltage / Frequency	380/400/415VAC (Phase-phase), 50/60Hz								
Voltage range	360~480 VAC (100% load)								
Frequency range	45~65 Hz								
Power factor	>0.99								
Current THDi	<3%								
Power walk-in	0-100% da 0 a 120 secondi (selectable)								
Standard features	Back Feed protection and splitted bypass line								
BYPASS INPUT									
Grid system	3PHS + N + PE								
Rated voltage / Frequency	380/400/415VAC (Phase-Phase), 50/60Hz								
Voltage range	Default: -20% ~ +20% Selectable: -5% ~ +25%								
Frequency range	± 2% (selectable from 1% to 6%)								
Bypass overload	110%, 60 minutes 125%, 10 minutes 150%, 1 minute								
OUTPUT									
Grid system	3PHS + N + PE								
Rated voltage / Frequency	380-400-415VAC (Phase-Phase), 50/60Hz								
Power factor	0.9								
Voltage THDv	<1% (from 0% to 100% linear load); <3% (non-linear load according to IEC/EN 62040-3)								
Voltage precision	± 1%								
Transient response	± 5%								
Transient recovery	20ms according to standard EN 62040-3, class 1								
Inverter overload	110%, 60 minutes 125%, 10 minutes 150%, 1 minute								
Frequency regulation from battery	50/60Hz ± 0.05%								
Synchronized range	2% (adjustable from ± 1% to ± 6% from the control panel)								
Synchronized slew rate	1 Hz/sec (selectable from 0.1 to 3)								
Crest Factor	3:1								
BATTERIES									
Battery type	Pb sealed acid, Wet, Ni-Cd								
Ripple	< 1%								
Number of batteries in series	Standard: 40 batteries 12V Selectable: 37-43 batteries 12V								
Nominal voltage	480Vdc								
Typical charging current	0,1 x C10								
Batteries arrangement	External								
External battery capacity	Selectable								
SYSTEM									
Efficiency - Normal operation	93.5%			94%			94.3%		
Efficiency - Eco Mode operation	98%								
Efficiency - Battery operation	94%								
Display	LED + LCD								
Protection degree	IP20								
Interface	Standard equipment: double RS232 port with monitoring software CD, dry contacts, 2 interface intellislot Optional: SNMP, JBUS/ModBUS converter RS485 port, ProfiBUS converter, Multilicence								
ENVIRONMENT									
Temperatura di funzionamento	0 ~ 40°C								
Storage temperature	-25 ~ 60°C								
Relative humidity	0 ~ 95% (no condensing)								
Noise (dBA at 1 meter far)	63~68				70 ~ 72				
Altitude	<1000m; load derated 1% per 100m, from 1000 ~ 4000m-20 ~ 70°C								
MECHANICAL DATA									
Dimensions W*D*H (mm)	800*850*1900		1000*850*1900			1500*1000*1900		2100*1000*1900	
Weight (Kg)	730	785	865	990	1090	1550	1750	2525	2700
Colour	RAL 7016								
Compliance	European directive: 2014/35/EU Low voltage directive; and 2014/30/EU Electromagnetic compatibility directive • Security: EN62040-1 • EMC: EN62040-2 • Performance: EN62040-3 (Voltage Frequency Independent) VFI - SS - 111								

Note: technical specifications and data could be changed without notification

MODEL	LB100 IGBTPF1	LB120 IGBTPF1	LB160 IGBTPF1	LB200 IGBTPF1	LB250 IGBTPF1	LB300 IGBTPF1	LB400 IGBTPF1	LB500 IGBTPF1	LB600 IGBTPF1	LB800 IGBTPF1
Nominal Power	100 kVA / 100 kW	120 kVA / 120 kW	160 kVA / 160 kW	200 kVA / 200 kW	250 kVA / 250 kW	300 kVA / 300 kW	400 kVA / 400 kW	500 kVA / 500 kW	600 kVA / 600 kW	800 kVA / 800 kW
MAIN INPUT										
Grid system	3PHS + PE									
Rated voltage / Frequency	380/400/415VAC (Phase-phase), 50/60Hz									
Voltage range	360~480 VAC (100% load) 240~360 VAC (65% load)									
Frequency range	45~65 Hz									
Power factor	>0.99									
Current THDi	<3%									
Power walk-in	0 ÷ 100% in 30 seconds (selectable)									
Standard features	Back Feed protection and splitted bypass line									
BYPASS INPUT										
Grid system	3PHS + N + PE									
Rated voltage / Frequency	380/400/415VAC (Phase-Phase), 50/60Hz									
Voltage range	Default: -20% ~ +20% Selectable: -5% ~ +25%									
Frequency range	± 2% (selectable from 1% to 6%)									
Bypass overload	110%, 60 minutes 125%, 10 minutes 150%, 1 minute									
OUTPUT										
Grid system	3PHS + N + PE									
Rated voltage / Frequency	380-400-415VAC (Phase-Phase), 50/60Hz									
Power factor	1									
Voltage THDv	≤1% (from 0% to 100% linear load); ≤3% (non-linear load according to IEC/EN 62040-3)									
Voltage precision	± 1%									
Transient response	± 5%									
Transient recovery	20ms according to standard EN 62040-3, class 1									
Inverter overload	110%, 60 minutes 125%, 10 minutes 150%, 1 minute									
Frequency regulation from battery	50/60Hz ± 0.05%									
Synchronized range	2% (adjustable from ± 1% to ± 6% from the control panel)									
Synchronized slew rate	1 Hz/sec (selectable from 0.1 to 3)									
Crest Factor	3:1									
BATTERIES										
Battery type	Pb sealed acid, Wet, Ni-Cd									
Ripple	≈0									
Number of batteries in series	Standard: 40 batteries 12V Selectable: 37-43 batteries 12V									
Nominal voltage	480Vdc									
Typical charging current	0,1 x C10									
Batteries arrangement	External									
External battery capacity	Selectable									
SYSTEM										
Efficiency - Normal operation	>95%									
Efficiency - Eco Mode operation	99%									
Efficiency - Battery operation	95%									
Display	LED + LCD									
Protection degree	IP20 standard (more upon request)									
Interface	Standard equipment: double RS232 port with monitoring software CD, dry contacts, 2 interface intellislots Optional: SNMP, JBUS/ModBUS converter RS485 port, ProfiBUS converter, Multilicence									
ENVIRONMENT										
Temperatura di funzionamento	0 ~ 40°C									
Storage temperature	-25 ~ 60°C									
Relative humidity	0 ~ 95% (no condensing)									
Noise (dBA at 1 meter far)	<65			<68					<72	
Altitude	<1000m; load derated 1% per 100m, from 1000 ~ 4000m									
MECHANICAL DATA										
Dimensions W*D*H (mm)	800*850*1900		1000*850*1900			1500*1000*1900		2100*1000*1900		3200*1000*1900
Weight (Kg)	890	900	975	1100	1300	1520	1670	2500	2830	3950
Colour	RAL 7016									
Compliance	European directive: 2014/35/EU Low voltage directive; and 2014/30/EU Electromagnetic compatibility directive • Security: EN62040-1 • EMC: EN62040-2 • Performance: EN62040-3 (Voltage Frequency Independent) VFI - SS - 111									

Note: technical specifications and data could be changed without notification

DALE

POWER SOLUTIONS

IN PARTNERSHIP WITH



Dale Power Solutions Ltd

Salter Road, Eastfield Industrial Estate,
Scarborough, YO11 3DU
Tel. 0330 999 3000
hello@dalepowersolutions.com
www.dalepowersolutions.com

GTEC Europe srl

Strada Marosticana, 81/13
36031 Dueville (VI), Italy
Tel. +39 0444.361321
info@gtec-power.eu
www.gtec-power.eu

GTEC France

france@gtec-power.eu