

## HE700U-B

3:3 50-80kVA



### FEATURES



TOWER UPS



ENGINEER  
INSTALLATION



USB  
CONNECTIVITY



HIGH EFFICIENCY

### HIGHLIGHTS

- Three level inverter topology with efficiency up to 95.5%.
- Wide input voltage range 138-485Vac
- Unity output power factor meaning the UPS can supply power to 100% unbalanced load.
- Up to 6 Strings of 12V 9AH batteries can be connected internally removing the requirement for an external battery cabinet for short run times
- Up to 6 units can operate in parallel with support for common battery arrangement.
- Power Walk In function, reducing the startup current impact to the system, and it can reduce the capacity of generator.
- LBS function can connect 2 independent groups of UPS systems to work in synchronisation, enhances the reliability of the system.

The HE700S-B series is ideal for protecting data centres and telecommunications systems, IT networks and critical systems in general, where the risks connected with poor energy supply can compromise the continuity of activities and services. The HE700S-B series is available in 50-60-80 kVA models with three-phase input and output and on-line double conversion technology in accordance with VFI-SS-111 classification (as set out in standard IEC EN 62040-3).

The HE700S-B is designed and built using state-of-the-art technology and components. It has a fully controlled IGBT rectifier to minimize the impact on the grid. It is controlled by a DSP (Digital Signal Processor) microprocessor, to provide maximum protection to the powered loads with no impact on downstream systems, and optimised energy savings.

### HIGH EFFICIENCY

State-of-the-art three-level inverters are used across the power range (50-80kVA) to achieve an operating efficiency of 95.5%. This technology approximately halves (50%) the energy dissipated in a year by traditional UPS, with an efficiency level of 92%. Its exceptional performance makes it possible to recover the capital investment cost in less than three years of operation.

### ZERO IMPACT SOURCE

The HE700S-B solves installation problems in systems where the power supply has limited power available, where the UPS is supported by a generator or where there are compatibility problems with loads that generate harmonic currents; the HE700S-B has a zero impact on its power source, whether this is the mains power supply or a generator:

- input current distortion < 3%
- input power factor ≥0.99
- power walk-in function that ensures progressive rectifier start up.

In addition, the HE700S-B plays a filtering and power factor correction role in the power network upstream of the UPS, as it eliminates harmonic components and reactive power generated by the power utilities.

### MAXIMUM RELIABILITY AND AVAILABILITY

Distributed parallel configuration of up to 6 units per redundant (N+1) or power parallel system. The UPS system will continue to operate in parallel even if one of the connection cables is interrupted (Closed Loop).

### FLEXIBILITY

With its flexible configuration, performance, accessories and options, The HE700S-B series is suitable for use in a wide range of applications:

- Suitable for powering capacitive loads, such as blade servers, without any reduction in active power from 0.9 lead to 0.9 lag
- On-line, Eco, Parallel operating modes.
- Frequency converter mode
- Cold Start to switch on the UPS even when there is no mains power present
- High power battery chargers to optimise charge time in the event of long runtimes
- Optional Dual input mains power supply

### ADVANCED COMMUNICATIONS

The HE700S-B is equipped with a 7" Touchscreen display providing UPS information, measurements, operating states and alarms in different languages.

The default screen displays UPS status, graphically indicating the status of the various assemblies (rectifier, batteries, inverter, bypass).

- RS232, RS485 and USB ports
- 2 slots for the installation of optional communications accessories such as SNMP and Volt-Free Relay Cards
- REPO Remote Emergency Power Off for switching off the UPS via a remote emergency button
- Input for the connection of the auxiliary contact of an external manual bypass
- Input for synchronisation from an external source

### INTERNAL BATTERY CONFIGURATION

The HE700S-B allows for connection of up to 6 x 40pcs of 7ah or 9ah batteries to be housed internally to the UPS system, reducing the requirement to have a separate battery cabinet for short autonomy requirements.

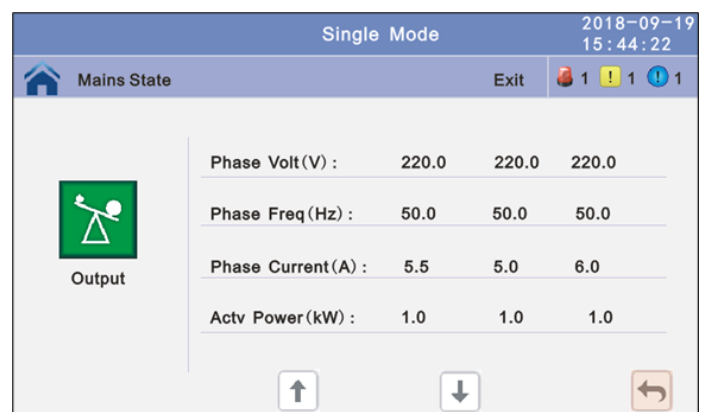
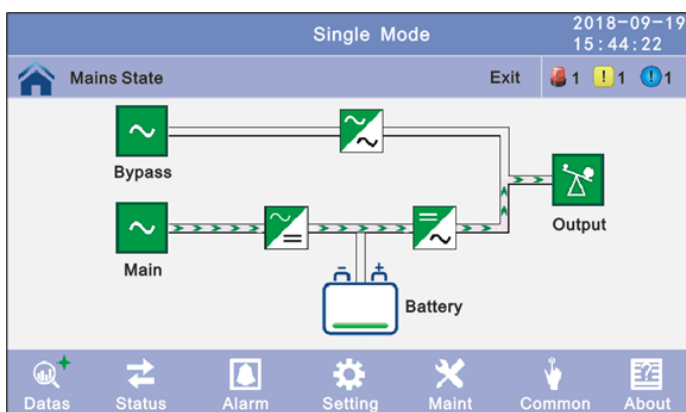

MODEL	HE73350U-B	HE73360U-B	HE73380U-B
<b>OVERVIEW</b>			
Active power (kVA)	50kVA	60kVA	80kVA
Active power (kW)	50kW	60kW	80kW
<b>INPUT</b>			
Nominal Voltage	380 / 400 / 415Vac (3Ph + N + PE)		
Operating voltage range	138-485VAC		
Operating frequency range	40Hz - 70Hz		
Power Factor	≥0.99		
Harmonic Distortion (THD)	≤3% (100% non-linear load)		
Bypass Voltage Range	220Vac Max.voltage: +25%(optional +10%,+15%,+20% ) 230Vac Max.voltage: +20%(optional +10%,+15% ) 240Vac Max.voltage: +15%(optional +10% ) Min. voltage: -45% (optional -20%,-30%) Frequency synchronize tracing range: ±10%		
Generator Input	Supported		
<b>OUTPUT</b>			
Output voltage	380 / 400 / 415Vac (3Ph + N + PE)		
Voltage regulation	±1%		
Power Factor	1.0 (Unity)		
Output Frequency	Synchronised with Input in normal operation, 50Hz / 60Hz selectable on battery mode		
Crest Factor	3:1		
Harmonic Distortion (THD)	≤2% with Linear load, ≤4% with Non-Linear load		
Efficiency	95.5%		
<b>BATTERY</b>			
DC Voltage	±240VDC		
Built-in Battery Quantity	6x40pcs (360pcs) max. 7 or 9Ah/12Vdc		
Charge Current	Max. 20A		Max. 40A
<b>SYSTEM FEATURES</b>			
Transfer time	UPS to Battery - 0ms ; UPS to Bypass - 0ms		
Overload	Inverter Mode: Load≤110% - 60 Minutes, Load≤125% - 10 Minutes, Load≤150% - 1 Minute		
Alarm	Overload, Mains Abnormal, UPS Fault, Battery Low etc.		
Backfeed	Supported		
Protections	Short Circuit, Overload, Overtemperature, Battery Low, Fan Fault		
Communications	USB, RS232, RS485, Parallel Port, REPO Port, LBS Port, Backfeed Port, Intelligent Slot, SNMP card (Optional) Relay card (Optional)		
<b>ENVIRONMENT</b>			
Operating temperature	0°C - 40°C		
Relative Humidity	0-95% (Non Condensing)		
Altitude	<1500m		
Storage Temperature	-25°C - 55°C (No battery)		
Noise Level	<585dB	<60dB	<62dB
<b>PHYSICAL</b>			
Dimensions DxWxH (mm)	1000 x 600 x 2000mm		
Net weight (kg) Inc. Batteries	1024	1026	1057
<b>STANDARDS</b>			
Safety	IEC/EN62040-1, IEC/EN60950-1		
EMC	IEC/EN62040-3, IEC61000-4-2, IEC61000-4-3, IEC61000-4-4, IEC61000-4-5, IEC61000-4-6, IEC61000-4-8		



# DALE

POWER SOLUTIONS

## Looking for something more bespoke?

With our own purpose-built, manufacturing facility, we're a one-stop shop for our customers providing design consultancy, manufacture and ongoing maintenance for our products.

## What we do

- An end-to-end service - design, manufacture, install, commissioning and servicing
- Experts in customised UPS solutions
- In-house mechanical and electrical design capability
- Solutions for any environment, application and location
- Industry-specific solutions including WIMES specified and PADS Approved UPS
- In-house project management team to manage the development and delivery of your product for exactly when you need it.

Get in touch with our team today to discuss your requirements.

[hello@dalepowersolutions.com](mailto:hello@dalepowersolutions.com)

0330 999 3000

[dalepowersolutions.com](http://dalepowersolutions.com)

# Your power in safe hands